

UNLESS OTHERWISE SPECIFIED: DIMENSIONS ARE IN MILLIMETERS SURFACE FINISH: TOLERANCES: LINEAR: ANGULAR:			FINISH:		DEBURR AND BREAK SHARP EDGES		DO NOT SCALE DRAWING		REVISION				
							POWERREEL		Simon Stevinweg 11 6827 BS Arnhem				
									TITLE: Powerreel 9000 kabelhaspel				
									DWG NO. PR9000			A3	
									WEIGHT: 140759.38			SCALE: 1:15	SHEET 1 OF 2

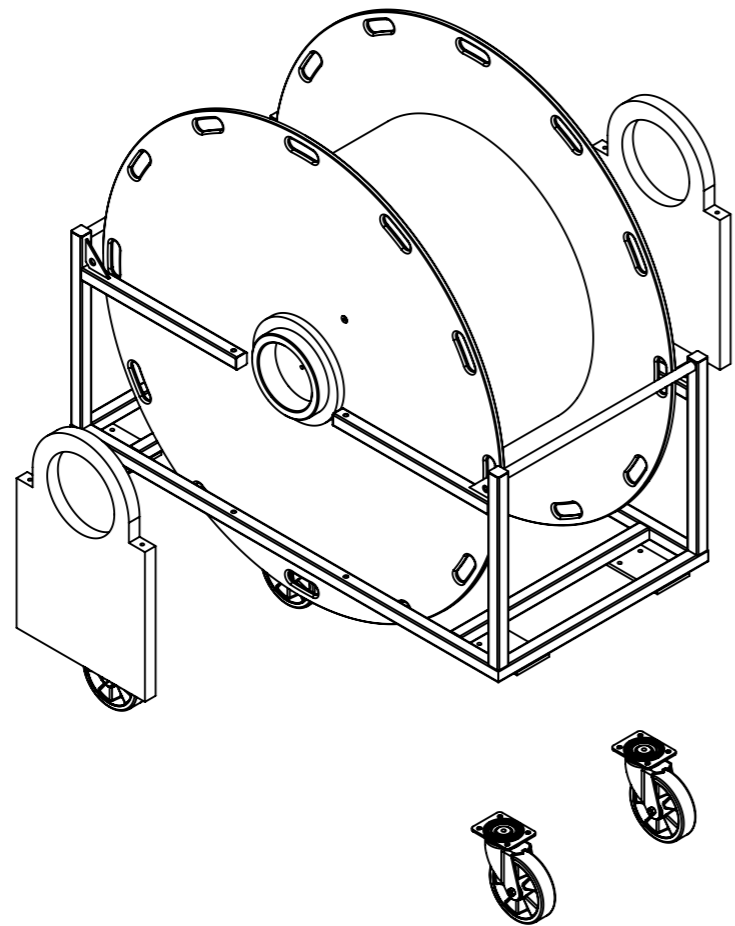

ITEM NO.	PART NUMBER	DESCRIPTION	QTY.
1	PR9006	Onderstel PR9000	1
2	PR9001	Plaat tbv kantelblok	1
3	PR9002	Schoor	1
4	PR9003	Vulring Ø50 x 5	2
5	PR9004	HMPE 1000 plaat	2
6	PR9005	Montage-as	1
7	PRO 9000	Kantelblok	1
8	PRO 3590	Haspelwang PR9000	2
9	PRO 3490	Haspel trommel 900 voor de PR9000	1
10	PRO 3290	Glijlager Ø250 voor de PR9000	2
11	GH-BH_200_G15		2
12	AM_LK_12x70x4_G		2
13	ALTH_200_20K_G15		4
14	GH-LH_200_G15		2
15	AM_LH_12x73x5_K		2

UNLESS OTHERWISE SPECIFIED: DIMENSIONS ARE IN MILLIMETERS SURFACE FINISH: TOLERANCES: LINEAR: ANGULAR:			FINISH:		DEBURR AND BREAK SHARP EDGES		DO NOT SCALE DRAWING		REVISION	
							POWERREEL		Simon Stevinweg 11 6827 BS Arnhem	
							TITLE:		Powerreel 9000 kabelhaspel	
							DWG NO.		PR9000	
							WEIGHT: 140759.38		SCALE:1:20	
									SHEET 2 OF 2	